



Gas Sensor GSE 517 for detection of Ammonia NH₃



Mode of operation

Through the diffusion of ammonia NH₃ into the inside of the measurement cell, a reaction with the electrolyte will take place. The product at the working electrode then oxidises. The electrolyte regenerates after the removal of the ammonia gas. In the case of long periods at a high gas concentration, the measurement cell can become saturated, which leads to a signal reduction until the electrolyte has ended the oxidation at the working electrode. The service life of the measurement probe will be shortened through the contact with gas. The ammonia measurement cell contains an organic electrolyte which evaporates.

The measured gas concentration is linear to the electrical output signal of the gas measurement probe. The potentiometers and the 3.5 mm jack connection for the calibration are accessible from the outside, and permits a "one-man" calibration.

When used in a pump system, the service life can be heavily reduced, as the electrolyte evaporates more quickly through the porous diaphragm. The measurement cell is sensitive to solvent vapours.

The **calibration gas** should be 75% of the measurement range, and must contain synthetic air as the carrier gas.

Performance Characteristics

Sensitivity:	at least 15 ppm
Measuring range:	max. 1000 ppm / linear
Standard calibration:	0...250 / 0...1000 ppm
Response time t 50:	max. 20 sec
Response time t 90:	max. 120 sec
Operating temperature:	-40 °C ... +40 °C
Start up after reconditioning:	max. 1 h
Pressure range:	atmospheric ± 10%
Air humidity:	15...90% non condensing the signal will increase for a short time
Position sensitivity:	none
Long term output drift:	< 10% / per 6 month
Life span at 20 °C:	at least 1 year longer by lower temperature

Cross sensitivity to other gases

Test gas	concentration of the test gas	display on the NH ₃ -Sensor
Ammonia NH ₃	100 ppm	100 ppm
Chlorine Cl ₂	5 ppm	0 ppm
Hydrogen Chloride HCl	10 ppm	0 ppm
Carbon Monoxide CO	100 ppm	95 ppm
Carbon Dioxide CO ₂	5'000 ppm	0 ppm
Phosphine PH ₃	300 ppm	0 ppm
Sulphur Dioxide SO ₂	20 ppm	5 ppm
Hydrogen Sulphide H ₂ S	20 ppm	40 ppm
Nitrogen Dioxide NO ₂	10 ppm	0 ppm
Hydrogen H ₂	3'000 ppm	3'000 ppm

Sensor electronic specification

Cable:	2-core cable, shielded
Power supply:	13.5...30 VDC
Sensor current:	max. 60 mA
Output signal:	4...20 mA / max. 60 mA
Operating temperature:	-40 °C ... +85 °C

Inspection (Maintenance)

The sensor and the electronic require an inspection.
Routine calibration is recommended once or twice a year.

Electronic

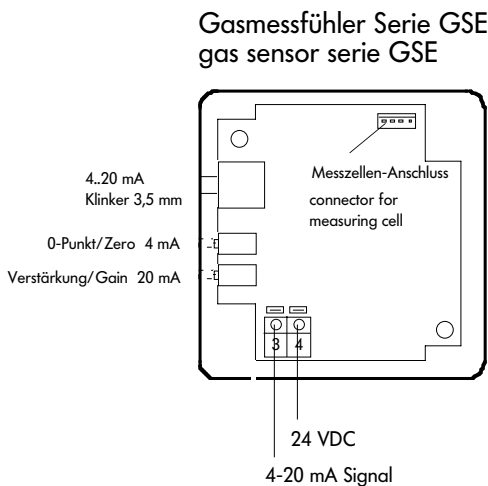

Dimensions

