



Gas Sensor GSE 667 for detection of Hydrogen Cyanide HCN



Mode of operation

Through the diffusion of hydrogen cyanide HCN into the inside of the measurement cell, a reaction with the electrode will take place. The product at the working electrode then oxidises. In the case of a HCN concentration, the electrode coating on the diaphragm will be used up. I.e., the measurement cell is only suitable for the occasional detection of HCN, and is therefore suitable for leakage monitoring.

The measured gas concentration is linear to the electric output signal of the gas sensor. The potentiometers and the Jack 3,5 mm connector are located at the side of the sub case on the sensor housing. This design allows a „one-man“ calibration.

When the sensor is mounted in a sampling system (Pump system), the lifetime can be shorter because the flow absorbs the electrolyte. The cell is sensitive to solvent vapours.

For a maximum accuracy the detector should be calibrated using a gas mixture containing 75% of the measuring range; the carrier gas has to be synthetic air.

Performance Characteristics

Sensitivity:	1 ppm
Measuring range:	max. 200 ppm / linear
Standard calibration:	0...20 / 0...50 ppm
Response time t 90:	max. 150 sec
Operating temperature:	-20 °C ... +50 °C
Start up after reconditioning:	max. 1 h
Pressure range:	atmospheric ± 10%
Air humidity:	15...90% non condensing the signal will increase for a short time
Position sensitivity:	none
Long term output drift:	5% / month
Life span at 20 °C:	at least 1 year longer by lower temperature

Cross sensitivity to other gases

Test gas	concentration of the test gas	display on the HCN-Sensor
Chlorine Cl ₂	1 ppm	≈-0.5 ppm
Ethylene C ₂ H ₄	100 ppm	< 55 ppm
Carbon Monoxide CO	300 ppm	<54 ppm
Hydrogen Sulphide H ₂ S	15 ppm	≈ 350 %
Sulphur Dioxide SO ₂	5ppm	5.5◇17.5ppm
Nitric Oxide NO	35 ppm	-17.5◇0 ppm
Nitric Dioxide NO ₂	5 ppm	-20◇-10 ppm
Hydrogen H ₂	200 ppm	0 ppm

Sensor electronic specification

Cable:	2-core cable, shielded
Power supply:	13.5...30 VDC
Sensor current:	max. 60 mA
Output signal:	4...20 mA/max. 60 mA
Operating temperature:	-40 °C ... +85 °C

Inspection (Maintenance)

The sensor and the electronic require an inspection. Routine calibration is recommended once or twice a year.

Electronic

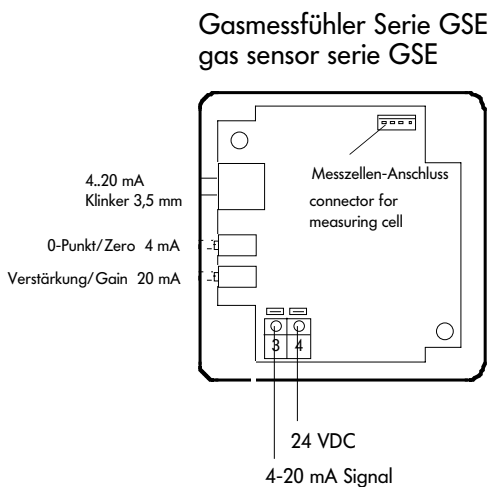

Dimensions

